

# X-RAY SCANNER

## ELEKTRON-SXRF-6080

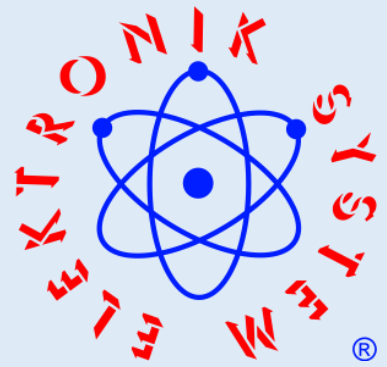

Ustronna 14  
89-606 Charzykowy

wykrywaczmetali@onet.eu  
elektron@metaldetektor.pl

+48 608 34 34 34



## PRINCIPLE OF OPERATION

### Destiny.

**ELEKTRON-SXRF -6080** It is designed for testing products in cardboard, plastic, PET, PE, vacuum, metallized, aluminum, glass and metal flat cans.

### How it works?

Popularly known as X-ray, it works by sending a beam of ionizing radiation, X rays, which is captured by the receiver. The inspected product moves between the lamp and the receiver. Detection is based on the principle of comparing the image of the reference product that the X-Ray Scanner has learned, the system detects the difference in density caused by the foreign body in relation to the image of the learned product. The easiest way to explain the principle of operation of the X-Ray Scanner - this technology is based on the detection of all foreign bodies, the density and specific gravity of which is higher than that of water (any body that immediately sinks into the water). Such foreign bodies include, first of all, metals, stones, glass, bones and hard plastic.

## „FROST” SYSTEM

The X-Ray scanner can be equipped with the "FROST" system, unparalleled in other devices, with a built-in intelligent heating and thermostat system, inside the control panel, which protects the internal electronics from moisture and cold. It is the only protection against sudden temperature changes during washing and prevents the absorption of moisture inside (for example, a cold machine washed with hot water).

## TECHNICAL DRAWINGS

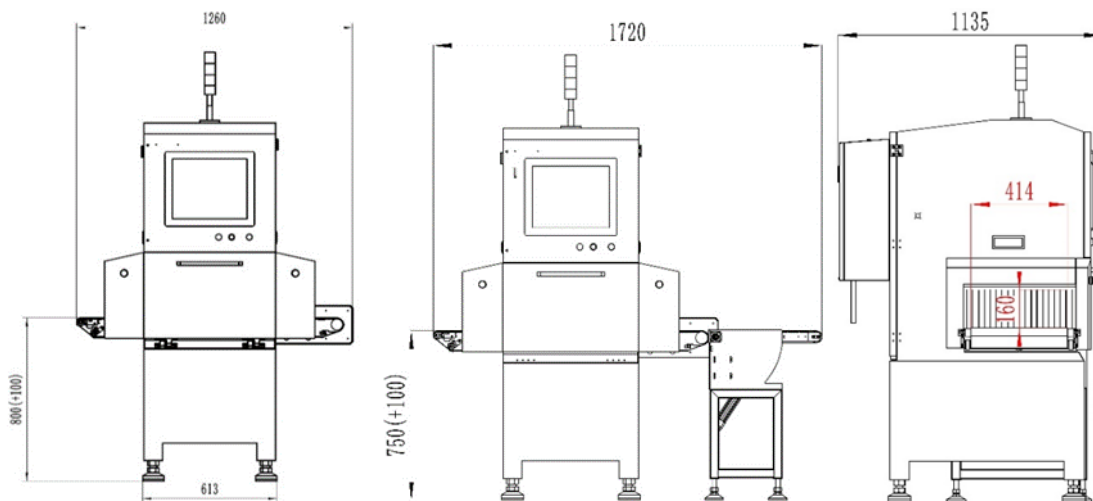

## MAIN FEATURES

- Detection level starting from - Fe, SUS from 0.3mm, for a diameter of 0.2mm by a length of 1.0mm.
- Stones, glass, hard plastic and bones.
- Detection window - width 600mm, height 180mm.
- X-Ray Lamp - Output - 80kV, 2.5mA, adjustable power, made in the USA.
- X-ray safety - safe up to Max. 0.23µSV / h in accordance with EU standards.
- 17 "color monitor.
- Operation - touch panel.
- High image resolution
- Built-in computer memory, 120Gb SSD operating disk.
- Built-in memory with self-learning function.
- Built-in 100MB data transfer and USB connection.
- Conveyor speed - 8 ~ 60m / min, The value is adjustable depending on the specificity of the product
- Max. product weight - 15 kg.
- Power supply - 200 to 240V, 50Hz, possibility of 110V, 60Hz.
- Working environment - Temperature - 5 ° C ~ 40 ° C (air-cooled or air-conditioned as standard), air humidity - 30% ~ 85% non-condensed steam.
- Construction and housing - made of SUS-304 acid-resistant steel.
- Separator - optionally, depending on the customer's needs, we use automatic rejection of detected impurities.

## LIST OF COMPONENTS

FUNCTION	NAME	MANUFACTURER
X-ray source	X-ray generator	VJ USA
X-ray receiver	X-ray detector	DT FINLANDIA
Device management	17 "touch monitor	iEi
Data processing	Industrial computer	TANK 820
Temperature and humidity control	Air conditioner	PFANNENBERG
Conveyor belt drive	Gear motor	ORIENTAL MOTOR
Speed regulation	Inverter	YASKAWA/OMRON
Electric protection	Switch	SCHNEIDER ELECTRIC /ABB
Connection between devices	Military connectors	PLT
Safety management	Limit switches	OMRON
Automation management	PLC driver	OMRON
Warning information	Optical-acoustic signaling device	SCHNEIDER ELECTRIC